

ELECTRONIC SOLUTIONS FOR CONTROL & PROTECTION OF SINGLE PHASE PUMPS

IP65
Enclosure

3 PIECES UNION
Integrated

NON-RETURN VALVE
built-in

WATER ACCUMULATOR
built-in



TROPICALIZED
electronic board

FREE POSITIONING
vertical, horizontal
or at any angle

'EXCESSIVELY FREQUENT STARTS' protection
with auto reset

'DRY RUN' protection
with auto reset

**DG
FLOW**

**PRESFLO starts and stops the pump
It substitutes traditional pressure switch/surge tank
systems while offering important advantages**

PRODUCT LINE, FEATURES & OPTIONALS



PRESFLO

SIMPLICITY
Fix start pressure



PRESFLO VARIO

VERSATILITY
Adjustable start pressure



PRESFLO MULTI

COMFORT
- Adjustable start pressure
- 3 litres tank
- Overcurrent protection

DIFFERENCES between models :

Water accumulator type

"SPRING-MEMBRANE" water tank

- "No ordinary maintenance required"
- "Engineered for long-life"



"SPRING-MEMBRANE" water tank

- "No ordinary maintenance required"
- "Engineered for long-life"
- Same water volume at different start pressure



"DIAPHRAGM" water tank

The tank is pre-loaded at 1.5 bar and has a capacity of 3 litres. It guarantees a comfortable accumulation volume, and it reduces the frequency of pump starts in the presence of leakages.



Start Pressure (cut-in pressure)

FIX "START PRESSURE"

3 models, each one with a factory preset value

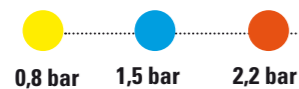

ADJUSTABLE "START PRESSURE"

Easily and intuitively by means of the rotary control knob.

Range: 0,8 bars ÷ 2,4 bars



ADJUSTABLE "START PRESSURE"

Easily and intuitively by turning a screw. You may use the supplied screw driver (pic.A)

Range: 1bars ÷ 5 bars

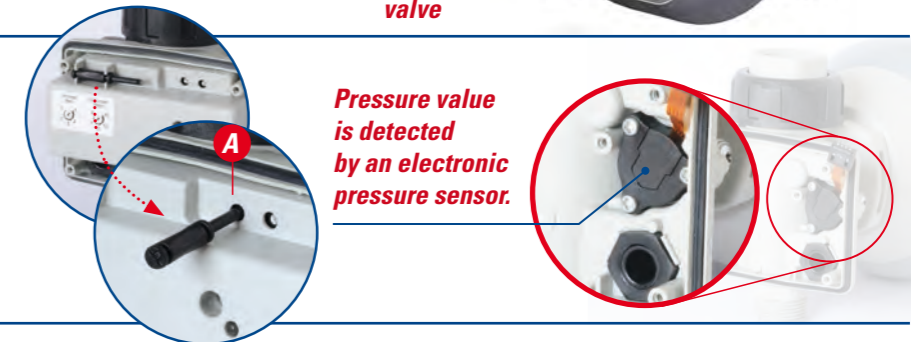

Max. Pump Power

PRESFLO 12: 1,5 Hp max pump power

PRESFLO 16: 2,0 Hp max pump power

PRESFLO VARIO: 2,0 Hp max pump power

PRESFLO MULTI: 2,0 Hp max pump power

Equipped with overload protection. The protection setting is easy by simply and intuitively turning a screw (pic.B)



KEY FEATURES COMMON ON ALL MODELS :

3 PIECES UNION integrated



Avoiding the need of expensive 3 pieces unions.

NON-RETURN VALVE built-in and inspectionable

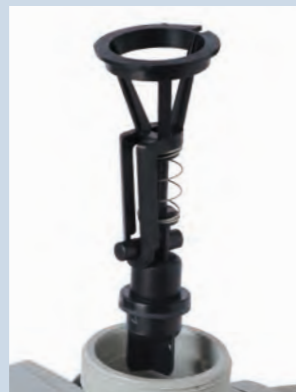

Avoid the need to install one

PRESSURE GAUGE easy-to-add



OPTIONAL: it can be added anytime.

FREE POSITIONING vertical, horizontal or at any angle



Thanks to the spring loaded valve.

PROTECTIVE COVER FOR ELECTRIC PARTS



To prevent damages during installation.

IP65 enclosure: able to protect against water jets

DRY RUN protection with automatic reset

EXCESSIVELY FREQUENT STARTS protection. Prevent pump overheating and damages. (PATENTED)

LOW HEAD LOSSES. the most performant on market today 0.3 bars at 100 lt/min

TROPICALIZED ELECTRONIC it saves and prolongs life of the electronic components.



PUMP MATCHING - ESSENTIAL CHECK

Carefully check the electric and hydraulic features and make sure they comply with those of the pump and the system, but in particular:

- Presflo 0.8 bars start pressure requires :**
 - pump head of at least 1.8 bars &
 - the water column between the device and the highest user point must not exceed 8 mtrs - less 2 mtrs tolerance = 6 mtrs (see picture : H) (otherwise raise control until conditions are fulfilled)
- Presflo 1.5 bars start pressure requires :**
 - pump head of at least 2.5 bars &
 - the water column between the device and the highest user point must not exceed 15 mtrs - less 2 mtrs tolerance = 13 mtrs (see picture : H) (otherwise raise control until conditions are fulfilled)
- Presflo 2.2 bars start pressure requires :**
 - pump head of at least 3.2 bars &
 - the water column between the device and the highest user point must not exceed 22 mtrs - less 2 mtrs tolerance = 20 mtrs (see picture : H) (otherwise raise control until conditions are fulfilled)

$H =$

- max 8 m ● 0,8 bar
- max 15 m ● 1,5 bar
- max 22 m ● 2,2 bar

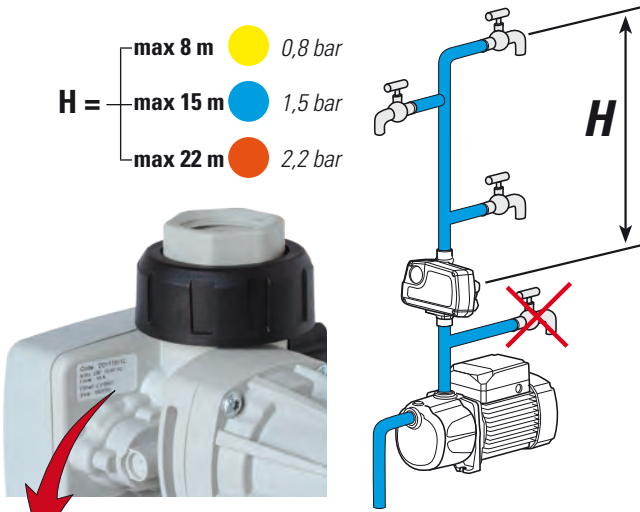

HEAD LOSSES

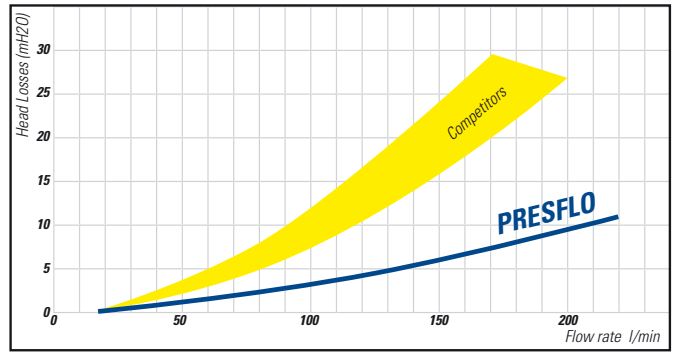

DIMENSIONS

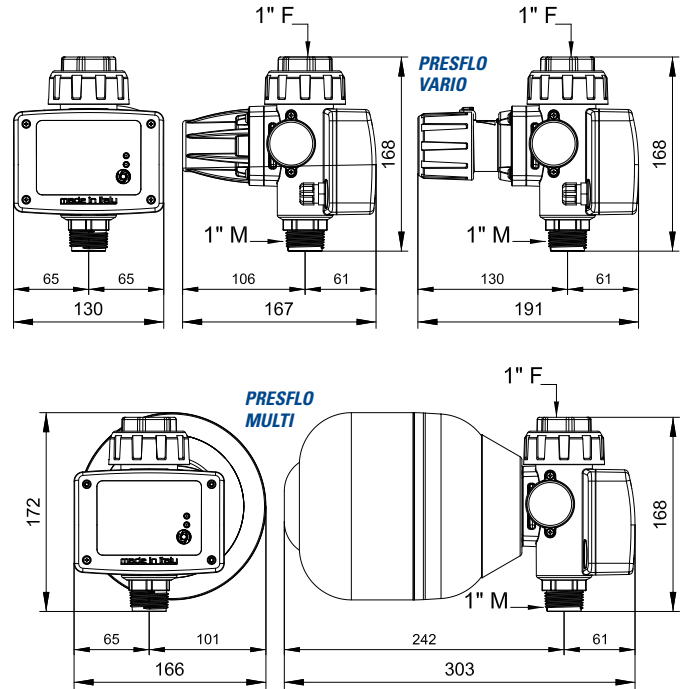

Models	Max. pump power		Start pressure bar	Max. current A	Water storage	Protections			Voltage V	Frequency Hz	Connections	cut-off flow rate	IP protection
	Kw	Hp				dry run	frequent starts	over current					
PRESFLO													
PF 1208	1,1	1,5	0,8	12	spring membrane	•	•		230	50/60	1" BSP	2 l/min	IP 65
PF 1215	1,1	1,5	1,5	12		•	•						
PF 1222	1,1	1,5	2,2	12		•	•						
PF 1615	1,5	2,0	1,5	16		•	•						
PF 1622	1,5	2,0	2,2	16		•	•						
PRESFLO VARIO													
PFV 12	1,1	1,5	0,8 - 2,4	12	spring membrane	•	•		230	50/60	1" BSP	2 l/min	IP 65
PFV 16	1,5	2,0	0,8 - 2,4	16		•	•						
PRESFLO MULTI													
PM 16	1,5	2,0	1,0 - 5,0	16	3 ltrs tank	•	•	•	230	50/60	1" BSP	2 l/min	IP 65

*110 Volts and NPT connection available on request

